

ISSOP2019: CHILDREN IN ARMED CONFLICT

Identifying Torture and Abuse Among Children in Conflict Zones (Part 1 and 2; 1130-1300; 1600-1730)

Coleen Kivlahan MD, MSPH

Professor, Family and Community Medicine

University of California, San Francisco



PLEASE NOTE

- All photos of injuries have been deleted from this slide deck due to the public nature of the website



Torture/abuse evaluation workshop overview:



Ideally, all attendees will come to BOTH workshops since they will follow on each other.



Workshop 1 will focus on the basics of forensic documentation torture and ill-treatment in children



Workshop 2 will be case-based. We will review photos, case summaries, challenging cases as a group.



Please bring photos and case summaries of children to the workshop to share. Slides from Workshop 1 will be available but not be repeating content exactly from Workshop 1

Workshop goals:

- a. Improve identification of effects of torture and ill-treatment of children
- b. Determine the safety and appropriateness of medicolegal documentation
- c. Improve the quality of reports in children

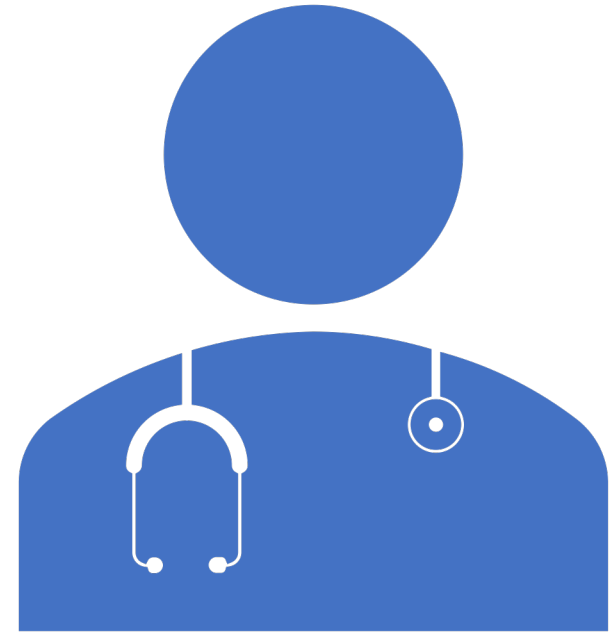

Workshop Outline:



Medical forensic documentation of children



Status of international standards



Clinical presentation of children at risk



Overview of key components of medicolegal examinations



Competencies required and environmental safeguards



Documentation standards; Legal and advocacy uses of medicolegal reports



Case studies and injury photo review



- “Effective medical and forensic documentation can bring evidence of torture and other ill-treatment to light so that perpetrators may be held accountable. Indeed, **the lack of investigation and of accountability perpetuates the practice of torture and other ill-treatment.**” (Juan Méndez, former Special Rapporteur on torture and other cruel, inhuman or degrading treatment or punishment)
- Scientific evidence obtained by an effective investigation, including ***impartial, independent and thorough forensic evaluations...*** Instrumental in overcoming a lack of objective evidence was the **medical affidavit, which played a major role in preventing future acts of torture.**

1. Medical forensic documentation of children

The Effects of Armed Conflict on Children



>1 in 10 children worldwide are affected by armed conflict



Direct effects of conflict include death, physical and psychological trauma, and displacement.



Indirect effects include inadequate and unsafe living conditions, environmental hazards, caregiver mental health, separation from family, and the destruction of health, public health, education, and economic infrastructure.

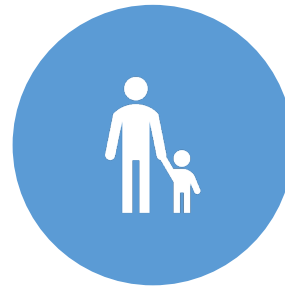

Armed conflict is both a toxic stress and a significant social determinant of child health.

The US Southern Border

- 750,000 people were apprehended at the southern border of the USA since Oct 2018 (300K more than FY18)
- The number of unaccompanied children/adolescents rose from 16,000 (2011) to 50,000 (2018)
- Number of families rose from 15,000 (2013) to 107,000 (2018), increasing from 3.5 to 26% of total apprehensions
- Migrants come from 3 of the top 6 countries in the world with the highest homicide rates;
- Reasons for fleeing: Guns and gangs #1, poverty #2, climate change #3
- ISSOP's June 2019 response called for the US to recognize and respond to the special needs and rights of these children



Case Study: Children from Central America

2018 PHR study: limited number of studies of children who resettled in developed countries, yet a high rate of trauma exposure, high rates of depression, PTSD, chronic pain, MS injuries, scars, and neuro-cognitive problems.

Reviewed findings from 180 child physical and psychological asylum evaluations in the USA from 2014-2018.



The Children:

89% from Northern Triangle countries of El Salvador, Guatemala, and Honduras.

78% physical violence, 18% sexual violence, 71% threats of violence or death, 59% witnessed acts of violence in their home countries. (60% gang-related, 40% by family members)

76% had at least one major mental health issue, 64% PTSD, 40% major depression, 19% anxiety.



"When you have no justice, what do you expect people are going to do? They're going to leave. All of those things weigh more than a threat of deterrence."

Pablo Alvarado, executive director of the Los Angeles–based National Day Laborer Organizing Network.



Medical forensic documentation

Use of forensic medicine and scientific investigation to document the health effects of torture and ill-treatment.

Context in children: abuse, torture, trafficking, sexual violence, detention, conflict, child marriage, FGC, other forms of acute or chronic persecution, and death.

Role of the Clinician

- Asylum applicant and torture survivors need corroborative evidence to bolster claims:
 - Medical-legal affidavits
 - Testimony of witnesses
 - Medical records, birth certificates, school records
 - Police reports, newspaper articles

Goals:

- Provide expert opinions on the degree to which findings corroborate with the allegations of abuse
- Document evidence of torture and ill treatment and effectively communicate such evidence to adjudicators
- Educate adjudicators on the physical and psychological evidence of torture and ill treatment

Physician Call to Action

“We must be prepared to diagnose and provide initial management for prevalent physical and mental health conditions among children exposed to armed conflict, such as physical harm, torture, depression, anxiety, and behavioral and psychosomatic complaints.”

(The Effects of Armed Conflict on Children. Sherry Shenoda, MD, FAAP, Ayesha Kadir, MD, MSc, FAAP, Shelly Pitterman, PhD, Jeffrey Goldhagen, MD, MPH, FAAP)

2. Status of international standards for documentation of children

TABLE 1 Timeline of International Agreements and Treaties Protecting Children and Medical Personnel From Armed Conflict

Year	Agreements and Treaties
1948	Universal Declaration of Human Rights
1949	The Geneva Conventions I–IV: The Geneva Conventions comprise 4 treaties and 3 protocols that regulate the conduct of armed conflict. Together, they form the basis of international humanitarian law. Aspects of the conventions of particular relevance to child health include the protection of the wounded and the sick, health and public health personnel, and humanitarian aid; the protected status of health facilities; the free passage of essential food, clothing, and medical supplies to the civilian population; and the protection of children who are orphaned or separated. ¹²
1951	The UN Convention Relating to the Status of Refugees: The UN Convention Relating to the Status of Refugees (1951) and the Protocol Relating to the Status of Refugees (1967), known collectively as the Refugee Convention, are the foundation for the protection of refugees in international law. The convention defines the term refugee and establishes specific rights of refugees and the obligations of states for the provision and protection of these rights. Because people who are internally displaced have not crossed an international border, they do not fall under the protection of the Refugee Convention. However, people who are internally displaced retain all their rights and protection afforded under human rights and international humanitarian law. ^{16,17}
1959	UN Declaration of the Rights of the Child
1967	UN Protocol Relating to the Status of Refugees
1977	Protocols I and II of the Geneva Conventions
1989	UNCRC: After the adoption of the Universal Declaration of Human Rights in 1948 and in recognition of the special need for protection of children, the UN adopted the Declaration of the Rights of the Child (1959). The declaration forms the basis for the UNCRC (1989), which is a legally binding treaty in which 40 substantive rights of children are established. Particular attention is given to children who are affected by armed conflict, setting out a basic minimum standard for their care and the promotion of their health and wellbeing. This includes the right to protection from violence and sexual exploitation; the right to freedom of thought and education, health services, and welfare services; and specific rights of children who are refugees, separated, and unaccompanied. ^{14,15} In 2000, the Optional Protocol on the Involvement of Children in Armed Conflict was adopted and aimed at preventing children <18 years old from being recruited for or taking part in hostilities. ¹⁸ ¹⁹ The United States ratified the optional protocol in 2002 but remains the only country that has not ratified the UNCRC.
2000	Optional Protocol to the UNCRC on the Involvement of Children in Armed Conflict

The 6 grave violations against the rights of children

- Killing and maiming of children
- Abduction of children
- Recruitment or use of children as soldiers
- Sexual violence against children
- Attacks against schools or hospitals
- Denial of humanitarian access.

(The commission of any of these violations constitutes a breach of international humanitarian law)

Convention on the Rights of the Child (CRC)

- States shall take all appropriate measures to ensure that the child is **protected against all forms of discrimination or punishment** on the basis of the status, activities, expressed opinions, or beliefs of the child's parents, legal guardians, or family members

Article 37 states Parties shall ensure that:

- (a) No child shall be subjected to torture or other cruel, inhuman or degrading treatment or punishment.**
- (b) No child shall be deprived of his or her liberty unlawfully or arbitrarily. The arrest, detention or imprisonment of a child shall be in conformity with the law and shall be used only as a measure of last resort and for the shortest appropriate period of time**

Limited guidance for Medical Evaluations of Child Torture Survivors

- **Istanbul Protocol:** Brief discussion of the psychological impact of torture on children and conducting an evaluation of a child who has been tortured is (beyond the scope of this manual).... If a child has been physically or sexually assaulted, it is important, if at all possible, for the child to be seen by an expert in child abuse.... Clinical considerations: 314. Symptoms of PTSD may appear in children. The symptoms can be similar to those observed in adults, but the clinician must rely more heavily on observations of the child's behavior than on verbal expression.
- **NICHD and APSAC's** interview protocols
- **United Nations Voluntary Fund for Victims of Torture 2016** on torture in children yet did not mention medicolegal documentation

UNICEF June 2019

“The **application of science to the protection of the rights** of the child with regard to torture, especially scientific aspects of health, education and social development, has significant implications for prevention, assistance, restoration of rights and the commitment to institutional efforts to combat impunity.

The responsibility of State institutions towards victims of torture and cruel or inhuman treatment acquires a very special significance and specific characteristics when children are tortured. **Torture is a traumatic interruption of the process of psychosocial maturing and social integration.”**

UNICEF June 2019

“Torture attacks those points of the person that sustain the rest, their name, family, body; the aim is for the person to lapse into a state of ambiguity. A part of the child is undefined, uncertain and ambiguous...This **destroys the mechanisms of security and belonging** that the child needs.

Few studies make a proper epidemiological examination of the phenomenon of torture in children and adolescents....**detailed medical and psychological examinations are considered unnecessary, which has the legal effect of opening the door to impunity** for possible crimes against humanity.”

Istanbul Protocol

- “Torture can harm a child directly or indirectly. The harm may arise from the child having been tortured or detained, from its parents or family members being tortured or from having witnessed torture or violence.
- When assessing a child suspected of having been tortured or having witnessed torture, the clinic should ensure that the child has the support of people caring for him/her and feels safe during the assessment.... The extent to which children can verbalize their thoughts and feelings depends on their age, level of development and other factors, such as the family dynamic, personality traits and cultural norms.”

Legal Distinction btw Torture and CAN

- They are **distinct violations** of children's human rights
- CAN committed by parents or parent-substitutes (WHO: "in the context of a relationship of responsibility, trust or power")
- Ill-treatment is not torture unless it causes severe pain or suffering
- Torture defined in Convention Against Torture by a "representative of the State/acquiescence of the State"
 - An act is not torture unless it is **done "for certain purposes** such as punishment, intimidation, coercion or discrimination."
 - The **motive in CAN is immaterial**
 - Torture is a human rights violation and a crime under international law, can also be a war crime

Cruel, inhuman and degrading treatment

- All physical punishment that intends to cause pain is degrading
- Non-physical punishment that belittles, humiliates threatens or ridicules the child is cruel and degrading
- Age of the victim is taken into account
- Psychological suffering alone can constitute torture or cruel/inhuman treatment
- Case law awards reparations to children who witness the deaths or torture of their families

When is Child Abuse Considered Torture?

- Study of 28 children with evidence of physical abuse, neglect and psychological abuse. Reviewed for types of injuries, duration of maltreatment, medical and physical neglect, social and family history, and history of prior abuse.
 - The median age was 7.5 years (9 months to 14.3 years)
 - 36% died
 - Duration of abuse ranged from 3.5 months to 8 years (median 3 years)
 - 93% of children were beaten and exhibited cutaneous injury
 - 21% had fractures, 89% isolation, 61% physically restrained, 89% restricted from food or water
 - 75% were terrorized using threats of harm or death to themselves or loved ones
 - 54% were degraded and/or rejected by caregivers

Child torture defined as:



At least two physical assaults, occurring over at least two incidents **Inflicted by child's caretaker**



A single extended incident, which would cause prolonged physical pain, emotional distress, bodily injury, or death AND



At least two elements of psychological abuse such as isolation, intimidation, emotional/psychological maltreatment, terrorizing, spurning, or deprivation.



Neglect is usually present, and may include failure to seek appropriate care for injuries and/or malnutrition



Results in prolonged emotional distress, pain and suffering, bodily injury/disfigurement, permanent bodily dysfunction, and/or death

Child Torture as a Form of Child Abuse. Journ Child Adol Trauma
Knox B, Starling S, Feldman K, Kellogg N, Frasier L, Tiapula S. 27 February 2014

Table 2 Physical injuries (*n*=28)

Physical injuries	% Yes	% No	% Unknown
Physical binding	61	21	18
Gagging	25	29	46
Restriction of bodily function	79	27	14
Cutaneous evidence of abuse	93	7	0
Beating	93	7	0
Kicking	36	11	54
Burning, contact	43	54	4
Burning, scald	18	75	27
Striking with objects	79	7	14
Stabbing	7	89	4
Asphyxiation	14	57	29
Forced position or standing	68	14	18
Forced exercise	25	39	36
Fractures	21	6	11
Action to aggravate pain of existing injury	43	29	29
Sexual abuse	21	64	14
Permanent loss body part or function	46	21	32
Death	36	64	0

Child-Centered Documentation Standards

- A child-sensitive approach is one that:
 - takes into account a child's age, maturity, and development
 - recognizes that children are particularly vulnerable to certain types of harm
 - grants children the liberal benefit of the doubt when assessing whether the evidence establishes the elements of the refugee/asylee definition
 - careful risk/benefit analysis for documentation

#3. Clinical presentation of children at risk

Preschool and Young School-Age Children

Feeling of helplessness, uncertainty about continued danger

Generalized fears that extend into other aspects of their lives

Difficulty describing emotions in words

Loss of previously acquired developmental skills, such as speech

Difficult sleep patterns

Separation anxiety

Hyperarousal, irritability, heightened startle

Avoidance, anger

Aggression and engage in traumatic play

School-Age Children

Persistent concern over their own safety and the safety of others

Guilt or shame

Constant retelling of traumatic events

Overwhelmed by feelings of fear or sadness

Aware of their own risk of death

Avoidance, Isolation, somatic symptoms

Protection of siblings

Difficulty learning

Ability to provide a reliable chronology of events and construct a coherent narrative

Adolescents

Self-conscious about their emotional responses

Fear, Vulnerability

Concern about being labeled different

Shame and guilt

Withdrawal from family and friends

Fantasies about revenge and retribution

Shift in thinking about the world and its dangers

Engage in self-destructive or accident-prone behaviors

Worrisome Additional Signs

Complex trauma, toxic stress exposure, witness to torture and death

Severe attachment problems

Serious emotional and behavioral regulation difficulties

Dissociative episodes and obsessive behaviors

Poor self-image, poor ability to socialize

Physical and cognitive deficits



Special Considerations for Children on the Move

- Country of origin
- Socio-economic conditions such as food access, forced labor, healthcare, housing
- Witness/exposure to violence at home, school, streets, gangs, police
- Education/literacy level
- Journey to safe country: food/water deprivation, physical injury, mental trauma
- Exposure to violence: extortion, trafficking, smuggling, kidnapping, physical/sexual assault, coercion, exploitation

Special Risks for Children on the Move

Border Crossing and Detention

- Treatment at borders
- Separation from family members or fellow travelers
- Length and conditions of confinement
- Physical and mental health access
- Identity documents

Post-Detention Release

- Sponsor: who, where, living conditions, treatment
- Education: school, language
- Social/community networks
- Vulnerabilities: shelter, food insecurity, abuse, exploitation

#4. Overview of Key Components of Asylum or Torture Medicolegal Examinations

Goal of Torture Documentation

Provide unbiased documentation of evidence of torture and ill treatment, & effectively communicate such evidence to adjudicators.

- Consistency - the degree to which findings corroborate the individual's allegation of abuse
- Common physical and psychological indicia of torture and ill treatment
- Where do you as a forensic expert fit into the legal effort to prove torture?

The UN definition of torture

“Any act by which severe pain or suffering, whether physical or mental, is **intentionally inflicted** on a person for such purposes as obtaining from him or a third person information or a confession, punishing him for an act he or a third person has committed or is suspected of having committed, or intimidating or coercing him or a third person, or for any reason based on discrimination of any kind, when such pain or suffering is inflicted by or at the instigation of or with the consent or acquiescence of a public official or other person **acting in an official capacity. It does not include pain or suffering arising only from, inherent in or incidental to lawful sanctions.**”

Asylum criteria reviewed

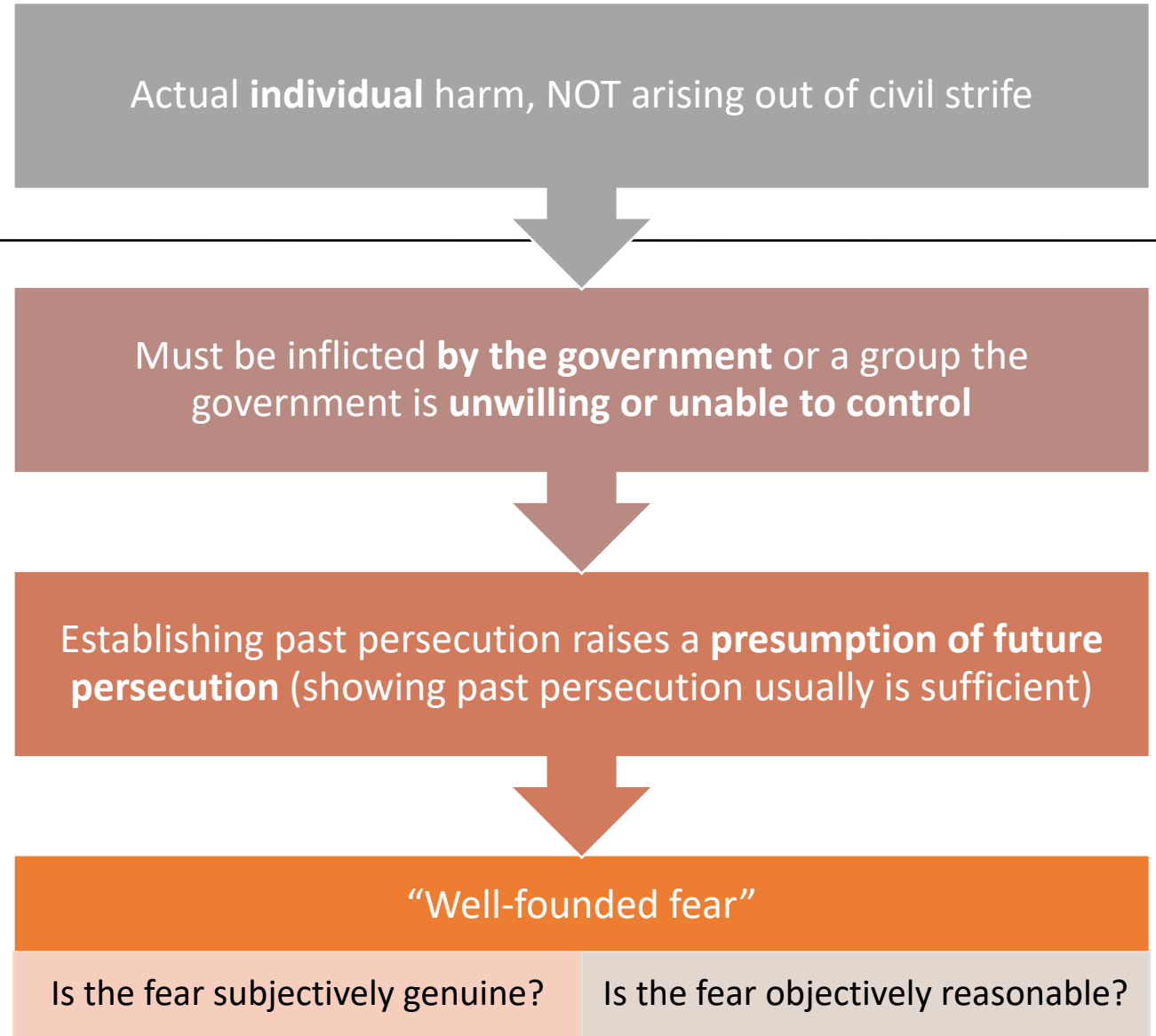

Asylum Eligibility: Protected Grounds

Persecution must be “on account of” at least one of 5 grounds. Must provide direct or circumstantial evidence that persecutor is motivated by victim’s protected characteristic.

Race

Nationality

Religion

Political Opinion

Membership in a Particular Social Group

Istanbul Protocol



The Manual on Effective Investigation and Documentation of Torture and Other Cruel, Inhuman or Degrading Treatment or Punishment



Sets out specific guidelines on how effective legal and medical investigations into allegations of torture and ill treatment should be conducted.



Officially recognized by the UN High Commissioner for Human Rights in 1999

Istanbul Protocol: Content

International legal standards

Ethical codes

Legal investigations of torture

General interview considerations

Physical evidence

Psychological evidence

Interpretations and Conclusions

Appendices (diagnostic tests, anatomical drawings)

Istanbul Protocol: Interpretation of Evidence

Goal is to correlate the degree of consistency between:

- History and symptoms with allegations of abuse
- Examination findings with allegations of abuse
- Behavioral/psychological observations with allegations of abuse
- Diagnostic test results, medical record findings (if available)

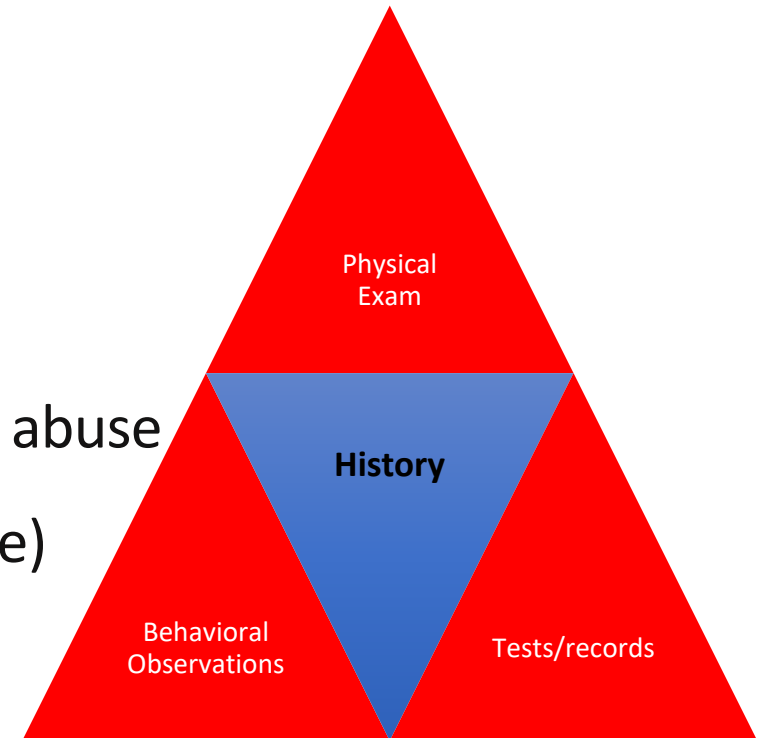

Main Differences Between Forensic and Non-Forensic Evaluations

- Not the start of a therapeutic or treatment relationship
- Setting of interview and your level of support may differ
- Clients may not understand the purpose of the evaluation
- Cultural Issues: such as beliefs about mental health
- Language barriers/Translation
- Documents using Istanbul Protocol language
- Trauma and More Trauma: detailed trauma history at first visit vs slowly over time
 - Known torture methods & maltreatment
 - Understand political and social ecosystem

Interview questions

- TED model: **tell me, describe to me, explain to me**
 - Tell me everything that happened the time you remember the most, or last time or first time
 - Tell me about something different, the worst thing
- What happened/What were you doing when?
- Where were you when? Where was your brother when that happened?
- Who was there?
- When did that occur?

Developmental interviewing of children

- **Avoid time and number** questions (how many times, what day, etc)
 - Time and number questions require knowledge of conventional and culturally driven learned concepts
 - Must be able to make inferences; to figure out what answer **MUST** be
 - For age 6-10, 60% got it wrong when asked about age at time of key events in their lives; Most do not know month of birthday until age 6; and few know the current month until age 9
- Stick with **What happened next**, and **When** questions can provide important data

Interview Flow

Identification and Introduction

Psychosocial History- Pre-Arrest

Past Medical History

Summary of Detention(s) and Abuse

Circumstances of Detention(s)

Prison/Detention Place Conditions

Allegations of Torture and Ill Treatment

Review of Symptoms Past and Current

Psychosocial History (post-arrest)

Interview Competencies

- Informed consent
- Privacy, confidentiality
- Empathy
- Pace/flow: Open ended questions, Hard questions, Inconsistencies, Wandering histories
- Managing level of trauma
- Documenting as you do exam
- Bias awareness

Opening the Interview

- Greetings: full introduction of clinician, interpreter, everyone in the room
- Ask what they understand about the nature of the evaluation.
- Informed consent
 - Gender expectations about clinician
 - Photographs
 - Use of interpreter
 - Limits of confidentiality
- Rights and expectations: breaks, water, bathroom, time allotted, role of students/observers
- Start with medical history, family history, social history, psychosocial history
- Detailed history of traumatic events

Difficulties in Recalling and Recounting

Factors directly related to the torture experience

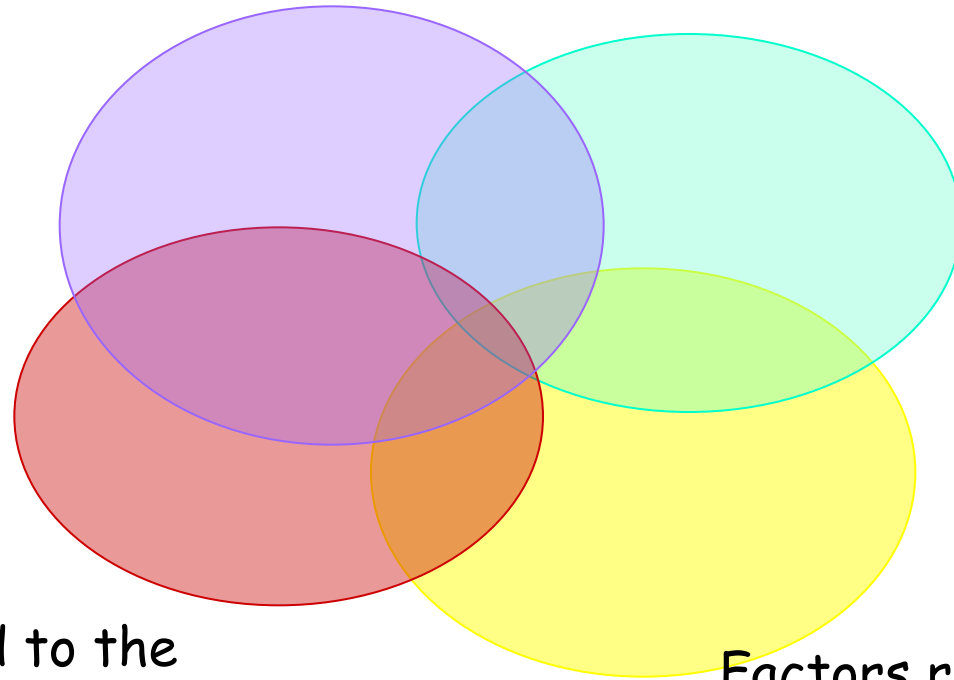

Cultural factors

Factors related to the psychological impact of torture

Factors related with the interview conditions or communication barriers

Trauma-Informed Care

- Recognize the realities of children's traumatic life experiences and respond to the effects of this trauma on children's health, development, and well-being.
- Knowledgeable regarding the effects of trauma, sensitive in our response to trauma, and help mitigate the effects of trauma.
- **Know when to document torture:** when the benefit to child outweighs harm, multiple victims, continued exposure to risk

Interviews for Sexual Violence

Requires Special Expertise



Sexual Violence

- Sexual abuse is common among torture survivors and ranges from forced nudity, shaming, and penetration, to death
- Most children know this is a taboo subject
- If you are not comfortable, they will not be
- Boys are even more reluctant to disclose sexual abuse than girls

SV Assault History

- Past medical, reproductive and sexual history
- Brief relevant social history
- Focused urogenital history
- Detailed history of the event(s)
- Date, time, and location of the assault
 - Name, identity, description, and number of assailants, as well as relationship to victim
 - Detailed account of violence
 - Method used: weapons, threats, and restraints
 - Use of medications/drugs/alcohol
 - Injuries that occurred during events
 - Post-assault hygiene/behavior
 - Note behavior and affect during the history

Medical and Psychological Needs Come First

- Treatment of serious injuries
- Sexual Assault injuries and infections
- Patient and staff threats
- Profound mental health stress
- Crisis intervention and support
- Translation and interpretation
- Childcare and in room support during the examination

Sexual Assault Typology in Boys

- Forced nakedness, humiliation
- Forced masturbation of the perpetrator
- Oral sex
- Forced masturbation of the victim
- Receptive anal intercourse
- Forced intercourse with family member or stranger

Silent Signs in Male Survivors

- Anger and irritability
- Complain about lower back problems, constipation or other GI problems
- Difficulty sitting comfortably
- Anxiety about homophobia
- Lose sexual interest
- Erectile dysfunction, urinary symptoms
- Withdraw from school, social or community activities



Day Two

**Identifying Torture and Abuse Among Children
in Conflict Zones, Part 2**

Physical Examination of Child Survivors

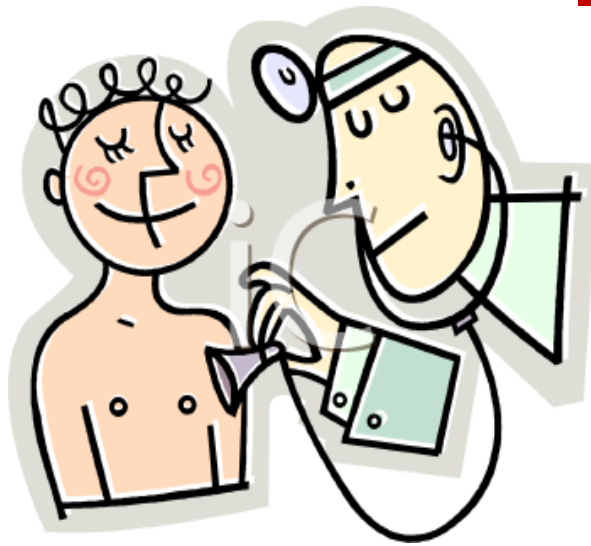

Istanbul Protocol: Levels of Consistency

Not Consistent With: lesion could not have been caused by the trauma described

Consistent With: symptoms or lesion could have been caused by the trauma described, but is non-specific and there are many other possible causes

Highly Consistent With: symptoms or lesion could have been caused by the trauma described, and there are few other possible causes

Typical of: this is an appearance usually found with this type of trauma, but there are other possible causes

Diagnostic Of: the symptom or lesion could not have been caused in any way other than that described

Not Related To: not related to alleged torture/ill treatment

Essential Components of Physical Exam

- Narrative of events guide focused exam
- Summary of physical exam findings
- Attribution for each finding/injury
- Photos
- Drawings
- Body Diagram

A FULL Physical Exam

- Head to toe exam
- **MOST CRITICAL**
 - **100% of SKIN examined**
- Other critical components
 - Mouth/dental
 - Ears, tympanic membranes, gross hearing
 - Bottoms of feet
 - Genital/anal
 - Hair
 - Gait/MS/Neurological

VII. General Physical Exam of the Patient

Mark all findings on body diagram using a number for each finding. For traumatic head injury, conduct a psychological/neurological exam or refer as appropriate. Remember to include chain of custody and to treat photographs as evidence.

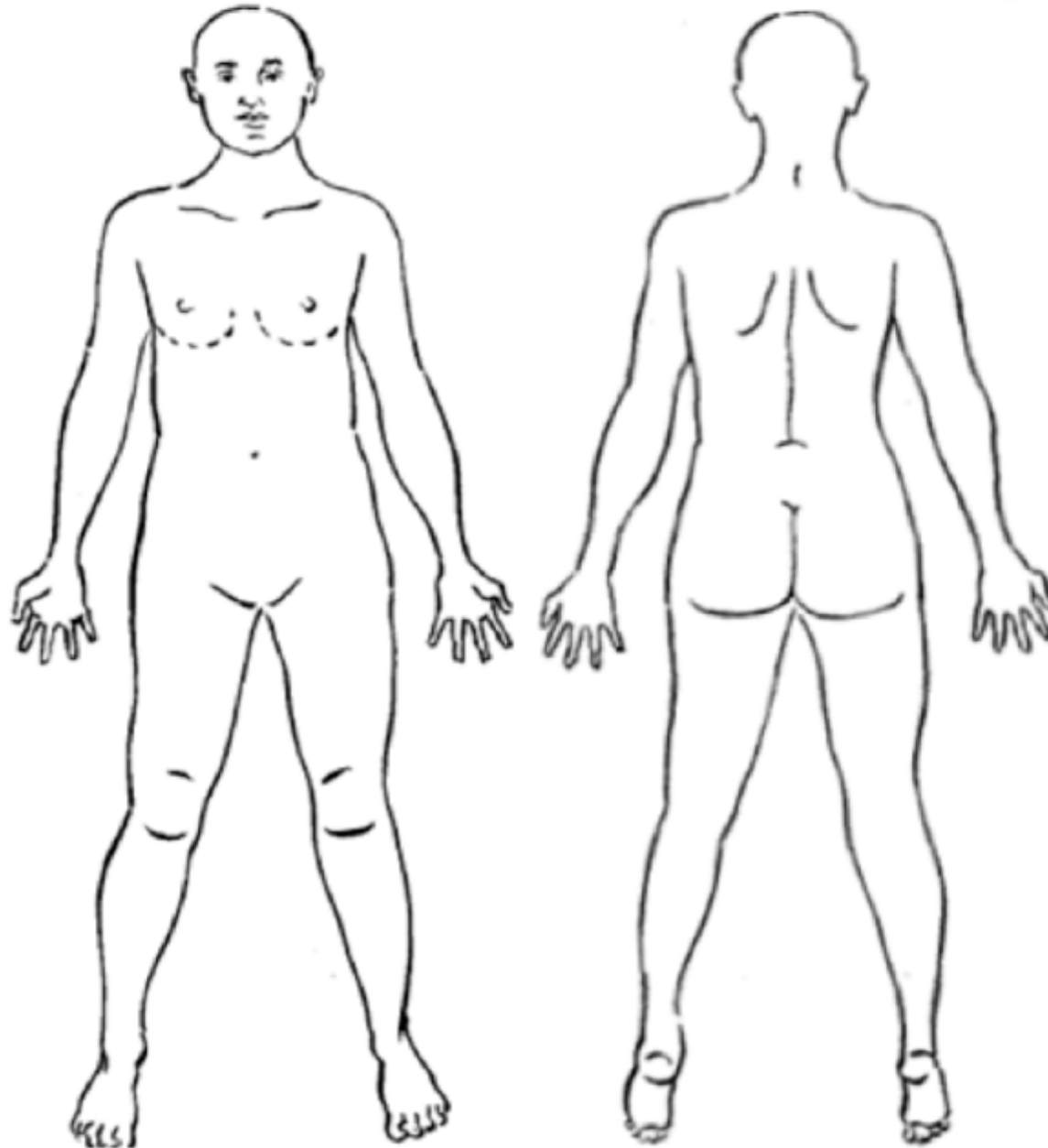

Factors Affecting Wound Appearance

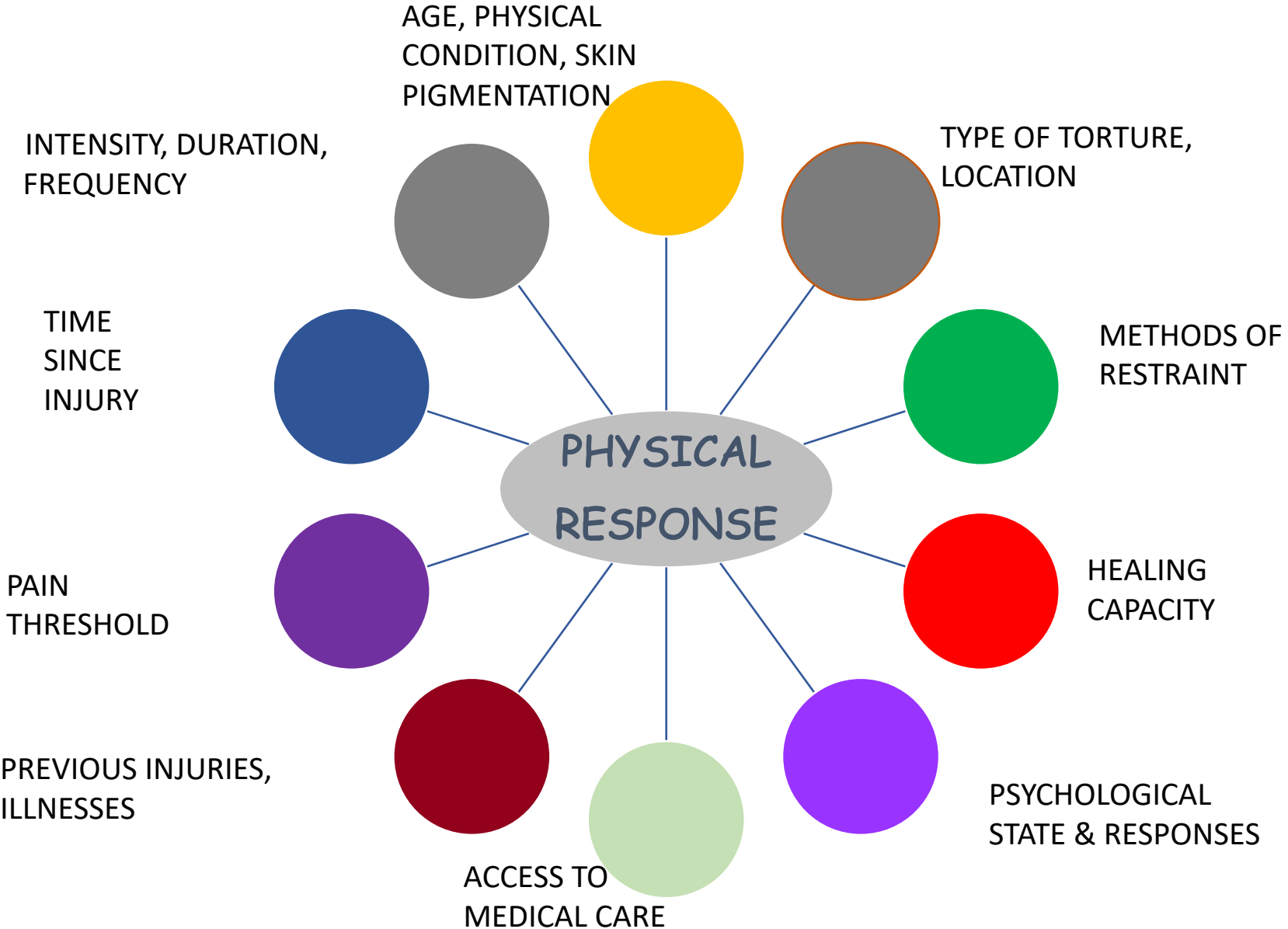

Question 1



This is a _____
_____ object measuring
_____ with _____ in
the center. It is sitting
on a _____
_____ and
casts a _____.

Describe this skin lesion (anterior thigh):

Shape:

Size:

Colors:

Surface:

Orientation:

Periphery:

Level in relation to surrounding skin:



Describe Each Lesion:

- Site: anatomical location
- Size: length, width, depth
- Shape: linear, crescent, stellate, curved
- Orientation: vertical, horizontal, oblique
- Colors
- Margins: regular/smooth, irregular/rough
- Wound type: laceration, incision, healed scar
- Other: involvement of deeper structures, surrounding landmarks

Main Types of Wounds

Lacerations

Tissue is cut, torn or burst of the skin or other tissues resulting from compression or stretching associated with impact by a blunt object or surface

Incision

Sharp edge, usually longer than it is deep, lack tissue bridging, clean, regular cut from sharp object

Abrasions

Superficial layer of tissue is removed resulting from friction against a rough surface

Contusions

Forceful blow to the skin and soft tissue, leaving the outer layer of skin intact.

Avulsions

Section of tissue is torn off, either partially or in total.

Bites, Burns

Wound Identification



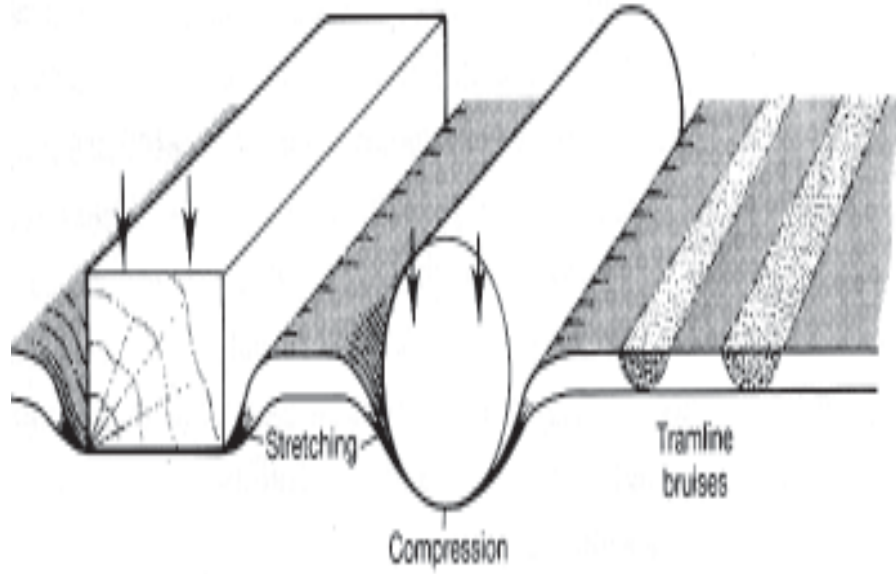

Blunt Trauma



Acute Injury Appearance

Interpretation of Physical Evidence: Case Example

A 32 year-old man alleges that he was beaten with a police baton. On physical examination, you observe the following:

How would you describe the level of consistency between the allegation of abuse and the findings on physical examination?

- A. Not consistent
- B. Consistent
- C. Highly consistent
- D. Typical
- E. Virtually diagnostic



[Courtesy of Amnesty International, The Netherlands.]

Interpretation of Physical Evidence: Case Example

Answer: C or D

The photograph shows a large 4 cm x 6 cm contusion with underlying edema and/or hematoma formation and a series of parallel linear abrasions that correspond to the ridges of a police baton.

These physical findings should be considered “highly consistent” with or “typical” of the alleged injury since the appearance has few other causes or is usually found with this type of trauma.

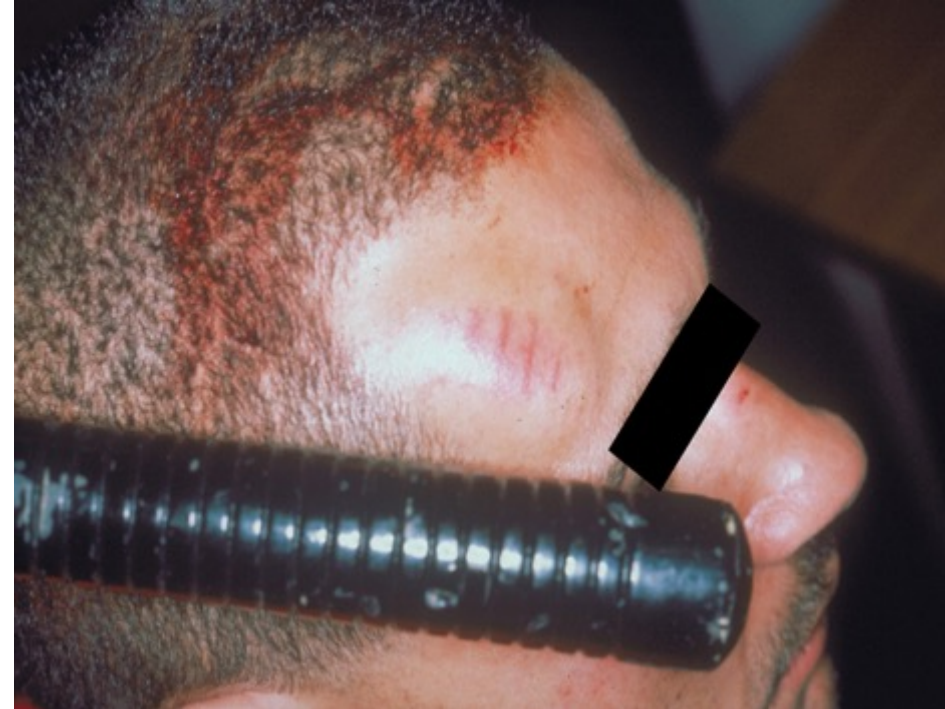

[Courtesy of Amnesty International, The Netherlands.]

Suspension

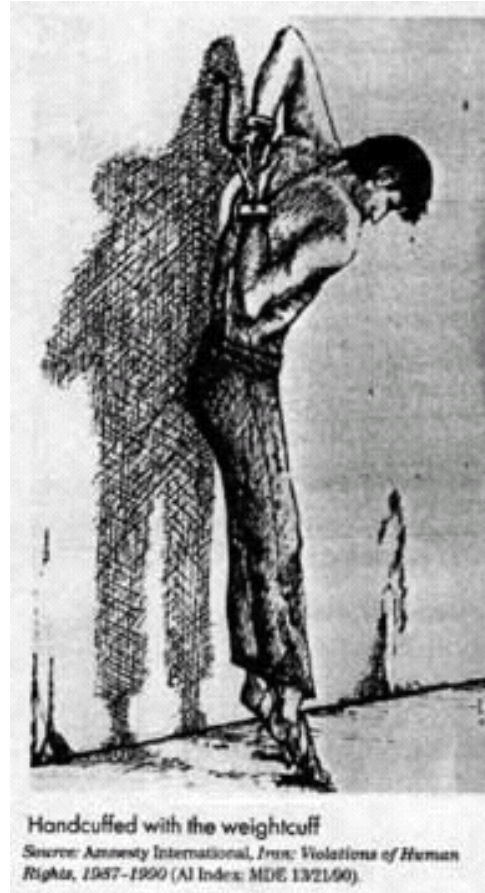

Handcuffed with the weightcuff
Source: Amnesty International, *Iran: Violations of Human Rights, 1987-1990* (AI Index: MDE 13/21/90).



Falanga-Beating Soles of Feet

Early

- Bruising, Swelling, Pain
- Ischemia, Compartment Syndrome

Late

- Limited long distance walking
- Pain increases during the day
- Can see night pain or RSD effects

Examination

- Awkward Gait
- Thickening of soles of feet; pigmentation changes, reduced arch



Uganda Child Victim Series

- Most common physical torture beating with sticks/wires
- Tying and dragging
- SV and pregnancy
- Forced abduction and executions
- Participate in killing in their own villages
- Withholding food and clothing
- Constant movement

Synergy for Justice report: Male SV in Syria

- Human rights report of 10 patients < age 18 when detained (age 9-17) (and 25 adult witnesses to child HR violations in detention)
 - Of the 5 girls, 4 of 5 experienced SV
 - 3/5 boys and 4/5 girls experienced forced nudity
 - 9/10 experienced physical violence
 - 4/10 with simulated executions
 - All detained in adult prisons in Syria
 - Ave duration detention 438 days
 - 20 unique detention facilities

Case Summaries

- 13 year old died in the arms of another detainee/witness after extreme physical and sexual violence
- High school student beaten more than 250 times witnessed by a female detainee
- Female detainee witnessed the beating of a 10 year old until blood came from ears/mouth and watched him thrown to the ground repeatedly
- One witness blindfolded next to a father and four young sons all shot
- 10 year old in solitary confinement for 5 months, threats to execute her mother
- 14 year old suspension torture, cigarette and lighter burns
- Young girl in case series witnessed naked boy with electrocution
- 21 children arrested on a school bus and detained for 9 months; anal rape for several of them, witnessed by others
- Children stepping over dead bodies to reach the toilet
- Babies taken away from mothers
- 2 adolescents electrocuted, simulated execution

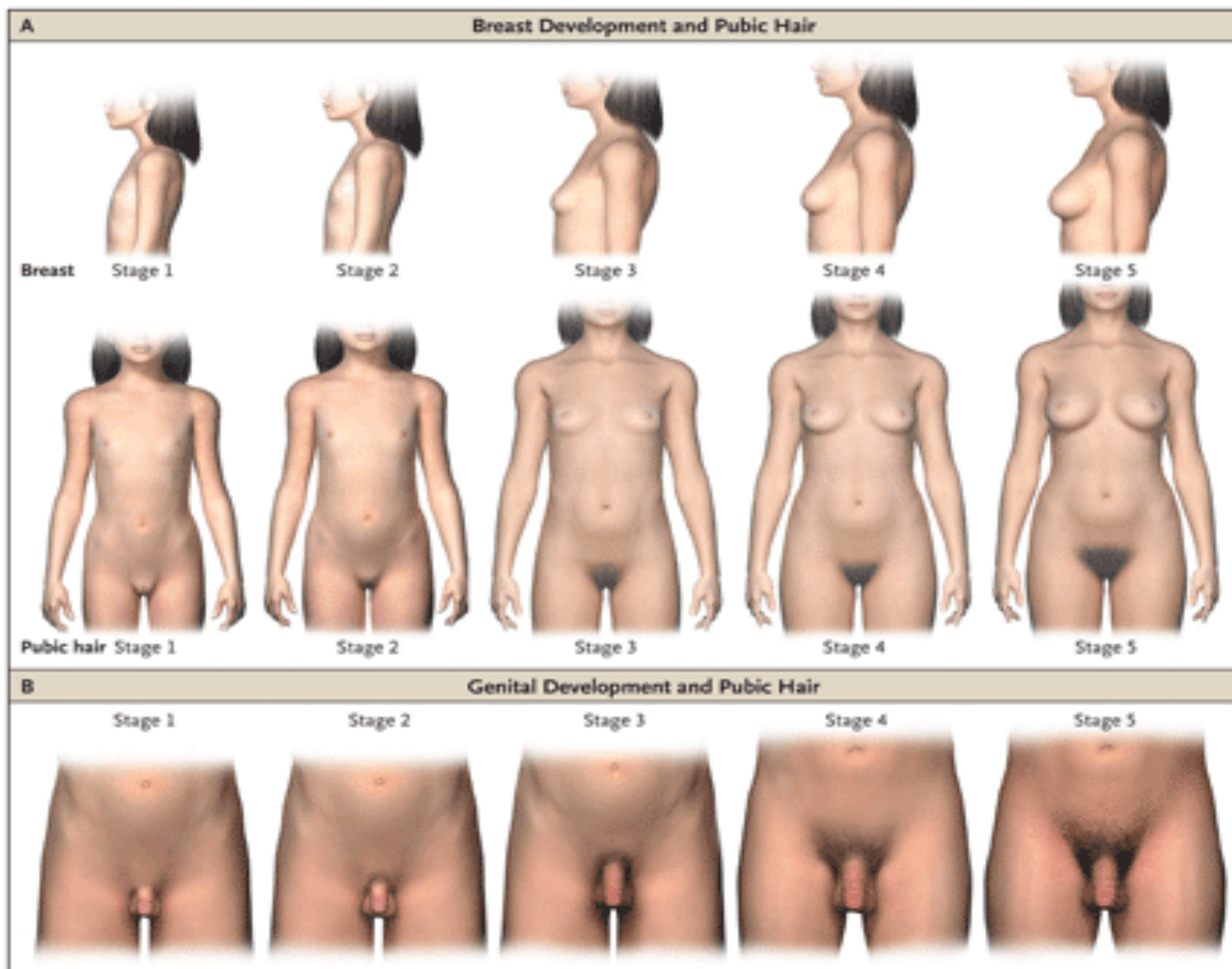

The Genital Examination

Female Genitalia

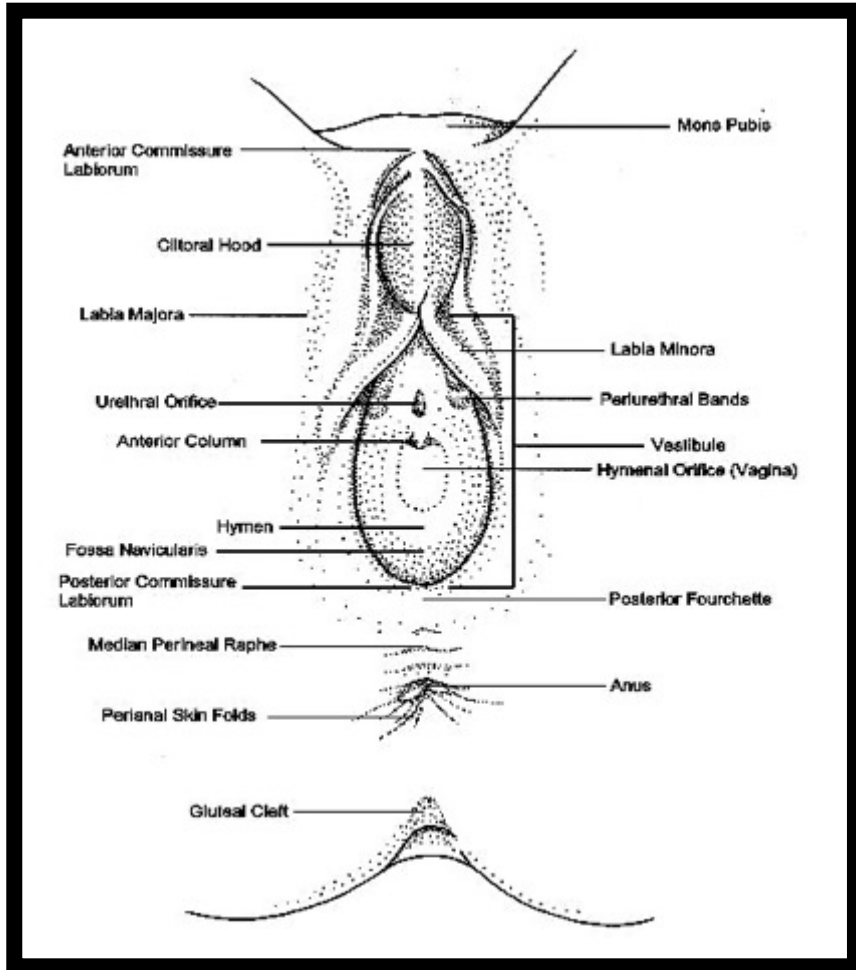

Male Reproductive Tract

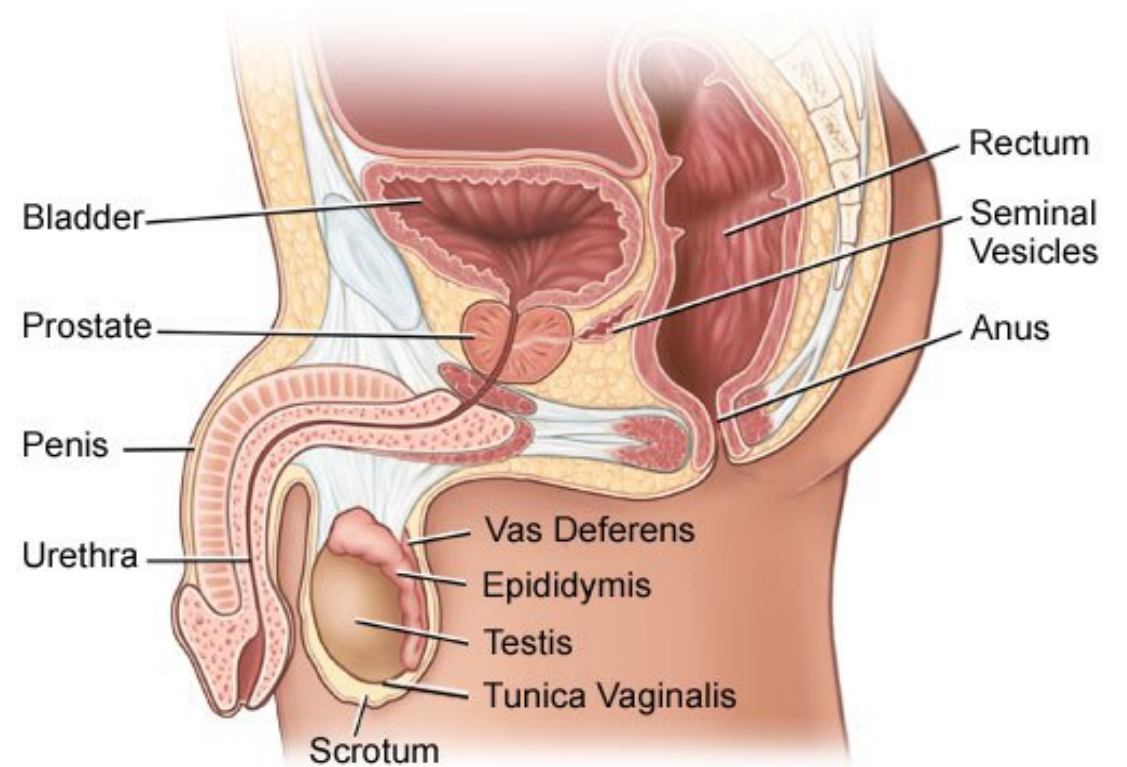

Female Genital Cutting/Circumcision/Mutilation

- WHO classification:
 - Type I – Partial or total removal of clitoris
 - Type II – Removal of clitoris and labia minorae, with or without excision of labia majorae
 - Type III – Creation of a flap covering introitus with artificial opening, using remnants of labia minorae or majorae (infibulation)
 - Type IV – Other procedures to female genitalia
- Usually not precise technique

Photos with rulers and ID

Name, DOB



استمارة التقييم الطبي للتعذيب والعنف الجنسي

رمز الحالة: T-YR-35



LDHR

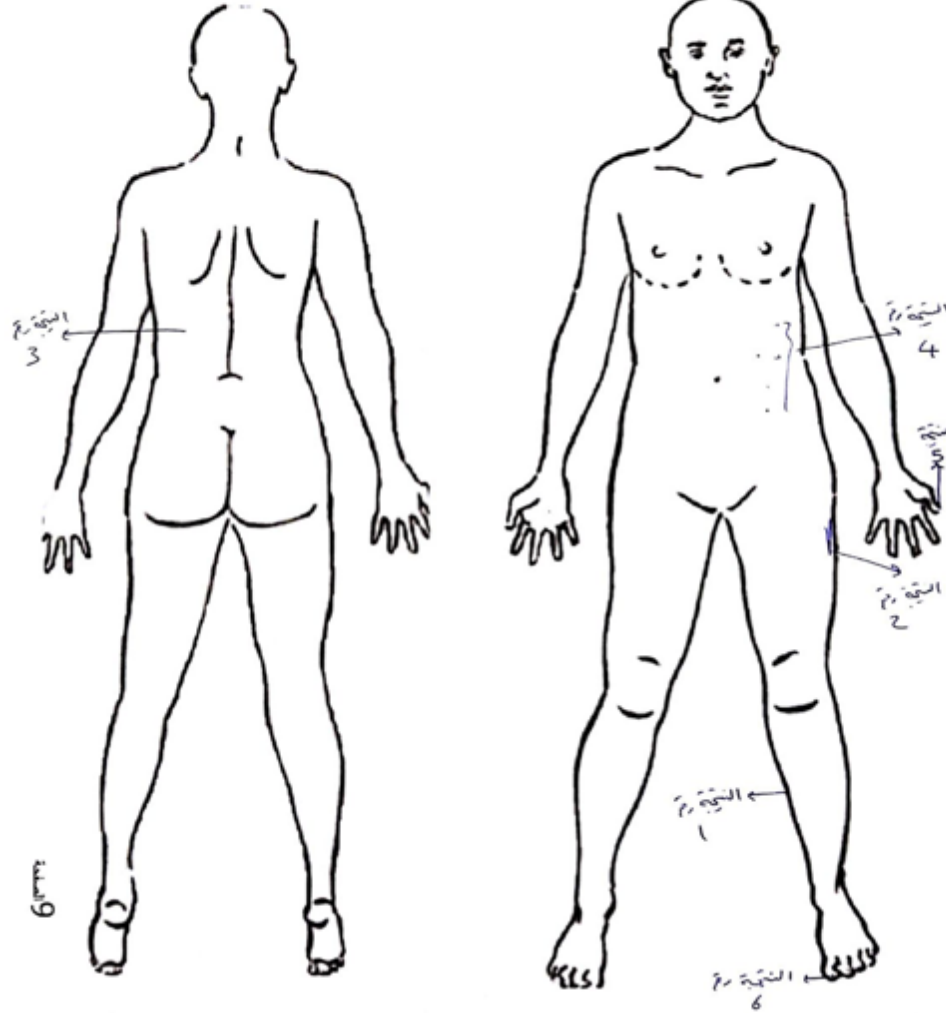

رمز الأذية	رمز الصورة	الموصف على الجسم	وصف الأذية	السبب الذي اصابه الناجي/ة للإصابة	درجة الأذى مع السبب المعطى
1	1	الوجه الأيسر للساق اليسرى	ندبة عمل جراحي طوليه بطول 14 سم مع وجود نديتين بيضويتين على جانبي الندبة السابقة في ثلثها العلوي احدهما زائدة الصباغ والأخرى بمحيط زائد الصباغ مركز أقل اصطباجا البعد بينهما وبين ندية العمل الجراحي غير متساوي قطر كل منهما حوالي 1 سم	ندبة العمل الجراحي بسبب كسر ساق ناجم عن حادث سير قديم والتدبنتين البيضويتين بسبب ثقب بمثقاب كهربائي أثناء التعذيب	ندبة العمل الجراحي غير ذات صلة في حين أن التدبنتين البيضويتين من الصعب الحكم عليهما باتهما من موجودات العمل الجراحي أو بسبب المثقاب الكهربائي ولكن بشكل عام متسقة
2	3-2	الوجه الوحشي للورك والفخذ الأيسر	ندبة عمل جراحي طوليه بطول 12 سم مع وجود ندبة دائرية الشكل بقطر اسم ذات مركز متقشر حواف مصطبغة غير واضحة	ندبة عمل جراحي لتبديل مفصل الورك الأيسر والندبة دائرية بسبب ثقب بمثقاب كهربائي	ندبة العمل الجراحي غير ذات صلة والندبة الدائرية من الصعب الحكم عليها باتهما من موجودات العمل الجراحي أو بسبب المثقاب الكهربائي ولكن بشكل عام متسقة
3	4	الظهر - منتصف الظهر على الجانب الأيسر	عدة ندبات متشابهه بأشكالها واحجامها واتجاهها متوازية كل منها بطول 5 ملم	حجامة (نوع من أنواع الطب الشعبي)	غير ذات صلة
4	-6-5 8-7	البطن	عدة ندبات متشابهه بالأشكال والاحجام دائرية كل منها بقطر 5 ملم ذات محيط زائد الاصطباج ومركز أقل اصطباجا - الحواف غير واضحة	حروق سجائر	متسقة

النتيجة 10

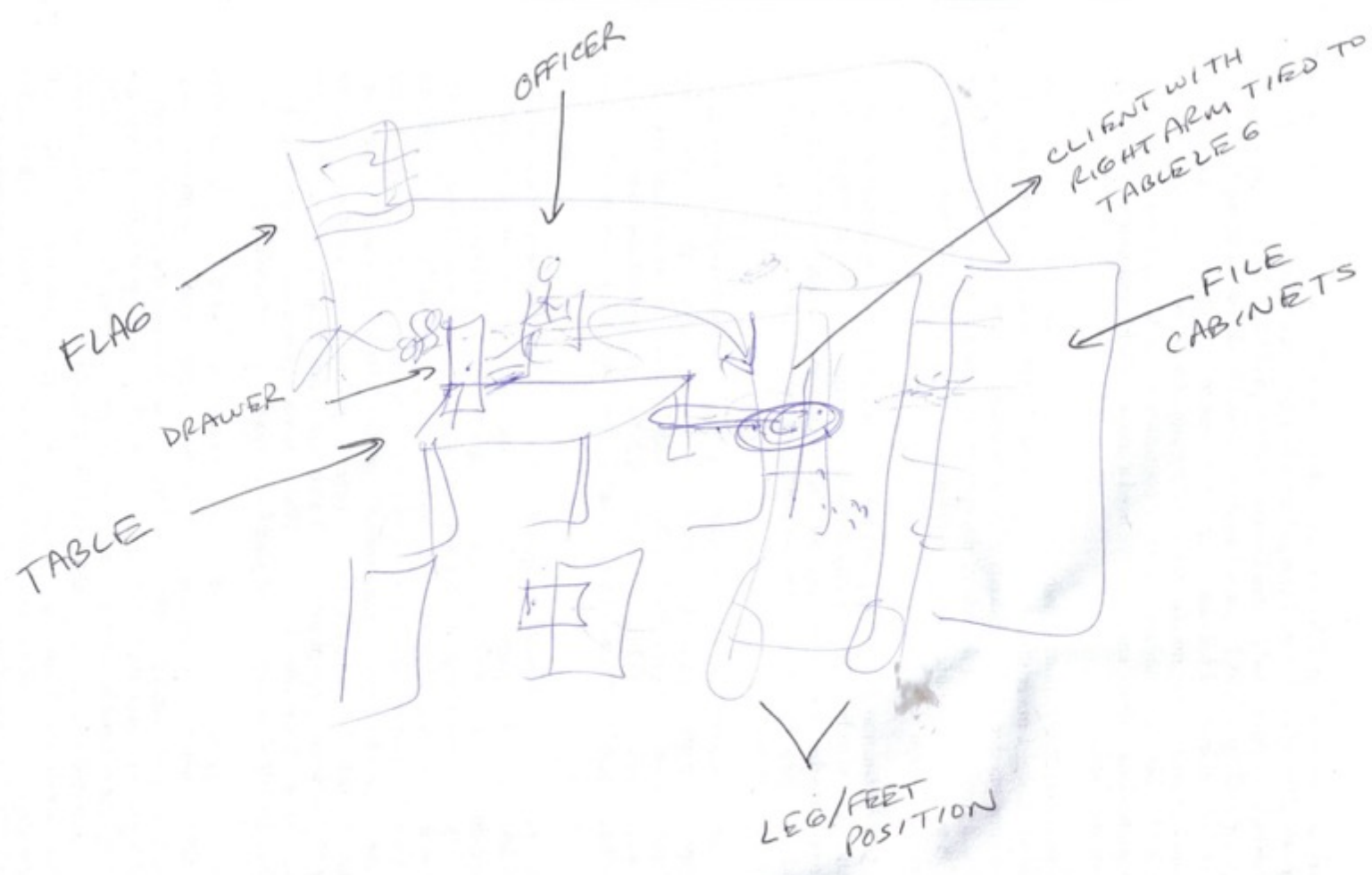

C. P. Alvarado

date



Best Practices for Writing Reports and Documentation Standards

Best Practices for Report Drafting

- Avoid unnecessary details (exact numbers, dates)
- Use significant quotations on alleged abuses
- Use headings or section numbers, orderly timeline
- Refer to client by name, not “victim” or “survivor”
- Be objective and impartial– stick to the facts
 - Use “he states,” “she reports”
 - Do not over-interpret or make conclusions about single findings
 - Do not use legal terms like torture or rape

Process of Report Drafting:

- Identify legal entity or organization requesting or collaborating on torture documentation
- Use PHR resources– sample affidavits, checklist, feedback, “Examining Asylum Seekers” manual
- Remember: a medical affidavit is only as good as the evaluation on which it’s based



LDHR CLINICAL REPORT



SUSPECTED CHILD* SEXUAL, PHYSICAL ABUSE AND TORTURE EXAMINATION (*up to age 18)

Date(s) / / Time(s) : Location of Examination

❖ Expert Qualifications

I (name) am a licensed physician/ Clinician in (country).

My specialty is . I have been practicing for years.

My medical/ Clinical training was at (institution).

In addition to my medical training and practice, my expertise is also based on the following:

- The UN Manual on the Effective Investigation and Documentation of Torture and Other Inhuman and Degrading Treatment or Punishment (Istanbul Protocol).
- Training on the medical documentation of torture and ill treatment, including sexual violence and other human rights violations.
- Specialist training in medical documentation of torture and ill treatment, including sexual violence against children.

I have conducted approximately medical evaluations of torture and ill treatment, including sexual assault, including medical evaluations of children.

Other special expertise (1-1 mentoring, literature review, clinical supervision, working with children, etc.):

Documentation
competencies required
and environmental
safeguards

Purpose of Exam and Report

- Provide the court with a description of findings
- Your expert judgment of the degree of consistency of those findings with the history
- Educate the judge
- Give voice to the client

Best Practices for Report Drafting

- Avoid unnecessary details (exact numbers, dates)
- Use significant quotations on alleged abuses
- Use headings or section numbers, orderly timeline
- Refer to client by name or “applicant”, not “victim” or “survivor”
- Be objective and impartial– stick to the facts
 - Use “he states” “he describes” “she reports”
 - Do not over-interpret or make conclusions about single findings
 - Do not advocate for THIS client
 - Do not use legal terms like torture or rape

Medicolegal Affidavit

- INTRODUCTION
 - Informed Consent
 - Demographics
 - Clinician qualifications
 - Evaluation overview
- NARRATIVE
 - History before alleged persecution
 - History of alleged persecution
 - History after alleged persecution
- CLINICAL FINDINGS-physical exam
- PSYCH/BEHAVIORAL EVALUATION
- REFERRALS
- ASSESSMENT
- CONCLUSION/IMPRESSION
- SIGNATURE

Competencies and Safeguards

- Training and mentoring
- Refuse to allow our profession or research skills to be exploited in any way for the purpose of torture, interrogation or punishment
- Medical personnel who know of instances or plans of torture must report them to the responsible national and international bodies
- Impartiality, privacy, confidentiality, informed consent
- Benefits and harms to ALL are considered, including environmental safety
- Information is secured

Informed Consent

- Informed consent for full exam given. I have obtained the patient's consent by discussing the following:
- Clinician Identification
- Confidentiality, including limitations
- Photographs
- Purpose and description of evaluation
- Risks of evaluation
- Patient comfort measures
- Patient has granted consent to share all information with: Designated attorney:
Yes No
- Referring entity: Yes No
- Can this report and photos, after de-identification, be used for training or reporting purposes?
- Yes No

Before Alleged Persecution/III-Treatment

Background Information: XX states that her life prior to adulthood was “very nice, we had 4 sisters total and we had a fun mother who showed us so much love.” She states that her father left the family for the USA when she was very young, and she saw him only once as she was older. She describes the home environment as cheerful, her mother had a strong faith, and supported her education.

Medical History Prior to the Alleged Events

Disability-none

Surgeries-none

Hospitalizations-none

Medications-no chronic medications

Pregnancies/fertility-G1P0 (1 pregnancy, no live children), currently 35 weeks gestation with a girl

Mental health concerns-none

Prior abuse-none

Injuries-none

Serious illnesses-none

Social History

Alcohol-none

Tobacco-none

Drugs-none

Current living situation-Lives with boyfriend who she knew for 2 years in Honduras, and has been living with him for about 1 year in the USA.

Employment-none

Education-Highest grade completed was a diploma in business from a vocational school at age 19. Completed primary and secondary schools.

Language-Spanish

Religion-Evangelical Christian

Family History

Family members-Mother, alive and well; 3 female siblings, she is the 3rd daughter in birth order; no contact with father. Marital status-single

Alleged Ill-Treatment

- **When**
 - **Who**
 - **What**
 - **Where**
 - **Why**
 - **How**
- At some point in February 2018, four men broke down the door in her house in XX. When they entered her home, she saw that it was Officer C and the same men from Mara 18 gang as before. They began throwing everything in the house, hitting doors, and screaming that XX would never get away from them, that no matter where she went, they would find her. Castro pushed a pistol in her face and told her she was going to die, that he liked seeing her afraid. He asked the other men “What are we going to do with this one?” The men hit and kicked her in the stomach and back. They grabbed her hair and pulled her from behind furniture, using her hair. There was a glass table in the house, and he cornered her against the table, pushed her down and she fell onto the table which broke into pieces. He was shooting his gun into the floor to “make me more afraid.” He then forced her to have intercourse again while he groped her breasts as he had done the prior month. He placed his gun next to her head as he raped her, saying he was the Authority. XX begged the gang members for help and they just laughed at her.
 - Two gang members then went out to the car and brought in a large plastic barrel filled with water. They said that this is “what they used when they torture people.” It was approximately 3 feet high and 2 feet wide. They put her head in the barrel and held her down in the water, then brought her head out allowing her to gasp for breath before dunking her back in the water repeatedly. She had tremendous fear and felt like she was drowning. C would hit the barrel loudly to scare her even more. He told her he did this to her because she had made a prior police report against him. They said they would come back and “I would not have peace, no matter where I went, they would find me.” As they were leaving, they used their guns to shoot all over the house. She stated that some of the bullets went through the walls, leaving holes.

Audience review of documentation errors/opportunities

Observations?

- In August of 2015, gang members attempted to kill R's father. The group shot his car 27 times and he was struck by bullets three times. He survived and returned to his home, where the client and her son were living at the time. She and her son observed him reenter the house, bleeding and in pain. At that time, the client and her son both became very frightened.
- The client knew that they were gang members because they identified themselves as such to her. They also used large firearms in their attack on her father, and only gang members were known to carry firearms of that sort.
- After this incident, the client's father stayed in his home, hiding from the gang members. The client began to be harassed by gang members on the street, who demanded that she say where the father was located. The gang members eventually threatened to kill her if she would not lead them to her father. As a result, she began to stay inside the house as much as possible. She began to have depressive and posttraumatic symptoms.

Observations?

“Wearing shirt, pants and bare feet, Mr. Y was placed in a cell 6’ x3’; he is 5’10” tall and he was unable to stretch out on the plywood floor. There was no bed, blanket, chair, sink or toilet. It was cold.

When he needed to go to the bathroom, he knocked on the door and was led to a toilet. There he drank water from a tap. He was given stale bread to eat. He was kept in these solitary conditions for 3 days.”

Observations?

- At age 15, she traveled from Brazil through Guatemala and Mexico, and paid a coyote \$1500. Near the US border she was put in a warehouse. There, 4 or 5 men raped her in a group.
- The person she was traveling with was acting erratically, regularly ingesting a powdery substance that seemed like a drug. During the trip, he abandoned her in a Mexican desert for three days without food or water. A local rancher found her and took her to his house. Her memories of this time were hazy and she could not remember stretches of that time. She recalled waking up in the rancher's house, naked, and she thinks that she was molested by the rancher.

Observations?

She often needed clarification, even in cases of simple yes/no questions. For example, when I asked “Did you ever experience physical or sexual abuse from anyone in your life?” she needed us to repeat the question twice before she understood it.

She had difficulty organizing the chronology of her history, jumping around to different events. Especially when discussing past traumas and emotionally charged events, she became distressed and had difficulties organizing her thoughts.

(age 13)

Consistency

12 year old male

There was no evidence that he was exaggerating his symptoms. In fact, at times he appeared to downplay or minimize the reports of his symptoms. Several times, he initially denied having a symptom, but then a different line of questioning revealed that he had in fact experienced the symptom. For example, he initially denied any sleep problems, but then later he noted that he often wakes up in the middle of the night, feeling anxious and thinking that someone is coming to rape him.

He denied hypervigilance, but during the interview, when someone dropped an object outside of the interview room causing a loud noise, he jerked in his seat and appeared unusually startled. These findings support that he is genuinely suffering from anxiety and PTSD.

Asylum

- Asylum
- Withholding of removal
- Convention Against Torture
- Persecution – Physical-Psychological
- Subjective and Objective Fear
- Unaccompanied children

Why do we this work?

Vicarious Traumatization

The reaction of the body and mind which occurs when one is exposed to a trauma narrative experienced by another person.

- All who work with survivors of trauma are at risk
- Is a normal reaction to hearing distressing narratives
- Can result in distress and symptoms of PTSD (e.g., nightmares, irritability, hypervigilance, anger)
- Feelings of demoralization and depression are also possible

Vicarious Traumatization Strategies

- Reflect and respond to your own responses and symptoms
- Self-Care: Physical, Emotional, Spiritual
- Avoid negative coping strategies
- Set clear boundaries with client: Focus on what you CAN do
- Seek supervision and support from colleagues
- Re-balance workload if possible

Vicarious Resilience & Post-Traumatic Growth

Working with survivors of torture reaffirms the value of our work, actually helps prevent burnout and brings us back to the reasons we entered medicine.

- Be inspired by our clients' commitment to survival
- Appreciate them as survivors (not just victims)
- Live differently, define problems differently, become more resolute
- Acknowledge and celebrate successes and satisfactions of this work

Engstrom, David; Gangsei, David Hernandez, Pilar. *Vicarious Resilience: A New Concept in Work With Those Who Survive Trauma*, Fam Proc 2007 46:229–241.

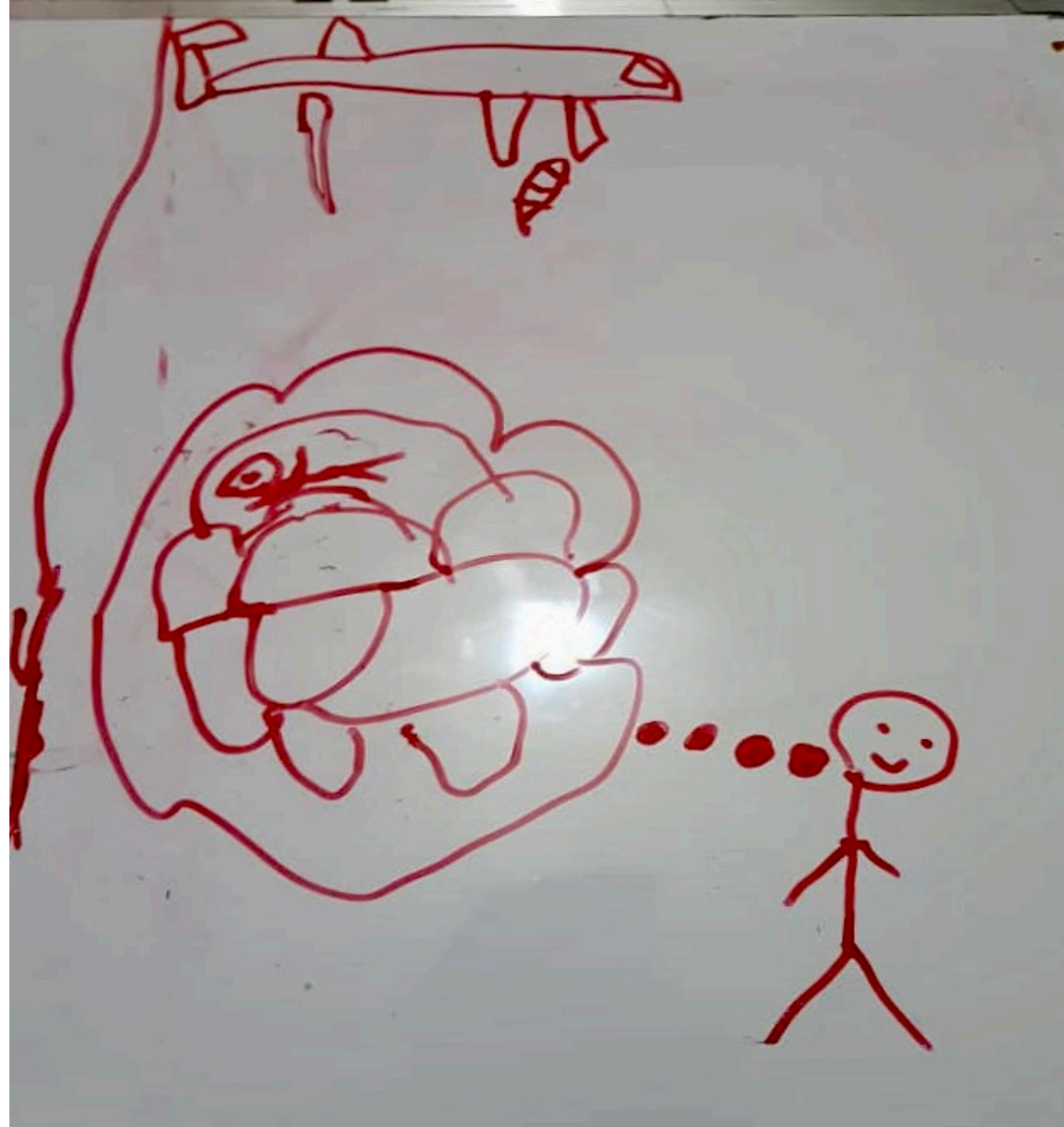

Case studies and injury photo review